

- ★ 100% EAS Guaranteed
- ★ Green Device Available
- ★ Excellent CdV/dt effect decline
- ★ Advanced VD MOSFETS

Product Summary



BVDSS	RDSON	ID
500V	1.1Ω	7A

Description

The XR7N50FR is the Advanced VD N-ch MOSFETS, which provide excellent RDSON and gate charge for most of the synchronous buck converter applications.

The XR7N50FR meet the RoHS and Green Product requirement 100% EAS guaranteed with full function reliability approved.

TO252-3L Pin Configuration

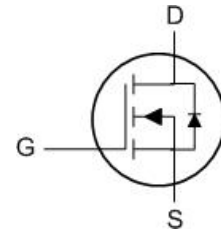
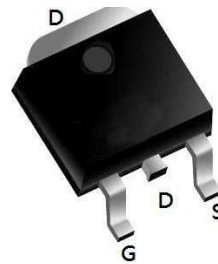

Absolute Maximum Ratings

Symbol	Parameter	Rating	Units
V_{DS}	Drain-Source Voltage	500	V
V_{GS}	Gate-Source Voltage	± 30	V
$I_D@T_C=25^\circ C$	Continuous Drain Current, $V_{GS} @ 10V^{1,6}$	7	A
$I_D@T_C=100^\circ C$	Continuous Drain Current, $V_{GS} @ 10V^{1,6}$	4.6	A
I_{DM}	Pulsed Drain Current ²	28	A
EAS	Single Pulse Avalanche Energy ³	360	mJ
I_{AS}	Avalanche Current	7	A
$P_D@T_C=25^\circ C$	Total Power Dissipation ⁴	79	W
T_{STG}	Storage Temperature Range	-55 to 150	$^\circ C$
T_J	Operating Junction Temperature Range	-55 to 150	$^\circ C$

Thermal Data

Symbol	Parameter	Typ.	Max.	Unit
$R_{\theta JA}$	Thermal Resistance Junction-Ambient ¹	---	62.5	$^\circ C/W$
$R_{\theta JC}$	Thermal Resistance Junction-Case ¹	---	1.58	$^\circ C/W$

Electrical Characteristics (T_J=25 °C, unless otherwise noted)

Symbol	Parameter	Conditions	Min.	Typ.	Max.	Unit
BV _{DSS}	Drain-Source Breakdown Voltage	V _{GS} =0V, I _D =250uA	500	---	---	V
ΔBV _{DSS} /ΔT _J	BV _{DSS} Temperature Coefficient	Reference to 25°C, I _D =1mA	---	6	---	V/°C
R _{DS(ON)}	Static Drain-Source On-Resistance ²	V _{GS} =10V, I _D =20A	---	1.1	1.4	Ω
V _{GS(th)}	Gate Threshold Voltage	V _{GS} =V _{DS} , I _D =250uA	3	---	5	V
ΔV _{GS(th)}	V _{GS(th)} Temperature Coefficient		---	---	---	mV/°C
I _{DSS}	Drain-Source Leakage Current	V _{DS} =500V, V _{GS} =0V, T _J =25°C	---	---	1	uA
		V _{DS} =400V, V _{GS} =0V, T _J =100°C	---	---	100	
I _{GSS}	Gate-Source Leakage Current	V _{GS} =±20V, V _{DS} =0V	---	---	±100	nA
g _{fs}	Forward Transconductance	V _{DS} =15V, I _D =3.5A	---	3.5	---	S
R _g	Gate Resistance	V _{DS} =0V, V _{GS} =0V, f=1MHz	---	1.1	---	Ω
Q _g	Total Gate Charge	V _{DS} =50V, V _{GS} =10V, I _D =7A	---	14	---	nC
Q _{gs}	Gate-Source Charge		---	3.9	---	
Q _{gd}	Gate-Drain Charge		---	7.1	---	
T _{d(on)}	Turn-On Delay Time	V _{GS} =10V, V _{DD} =250V, R _G =25Ω, I _D =7A	---	---	---	ns
T _r	Rise Time		---	---	---	
T _{d(off)}	Turn-Off Delay Time		---	22	---	
T _f	Fall Time		---	---	---	
C _{iss}	Input Capacitance	V _{DS} =25V, V _{GS} =0V, f=1MHz	---	556	---	pF
C _{oss}	Output Capacitance		---	79	---	
C _{rss}	Reverse Transfer Capacitance		---	14	---	

Diode Characteristics

Symbol	Parameter	Conditions	Min.	Typ.	Max.	Unit
I _S	Continuous Source Current ^{1,4}	V _G =V _D =0V, Force Current	---	---	7	A
V _{SD}	Diode Forward Voltage ²	V _{GS} =0V, I _S =20A, T _J =25°C	---	---	1.4	V
t _{rr}	Reverse Recovery Time	I _F =5A, di/dt=100A/ μs, T _J =25°C	---	108	---	nS
Q _{rr}	Reverse Recovery Charge		---	295	---	nC

Note :

1 The data is tested by surface mounted on a 1 inch² FR-4 board with 2OZ copper.

2 The data is tested by pulsed pulse width is 300us duty cycle is 2%

3 The EAS data shows Max. Rating at the test condition is V_{GS}=0, V_{DD}=50V, V_{GS}=10V, L=15mH, I_{AS}=7A.

4 The power dissipation is limited by 150°C junction temperature

5 The data is theoretically the same as I_{DM} and I_{DM(A)} in real applications should be limited by total power

dissipation.

Typical Characteristics

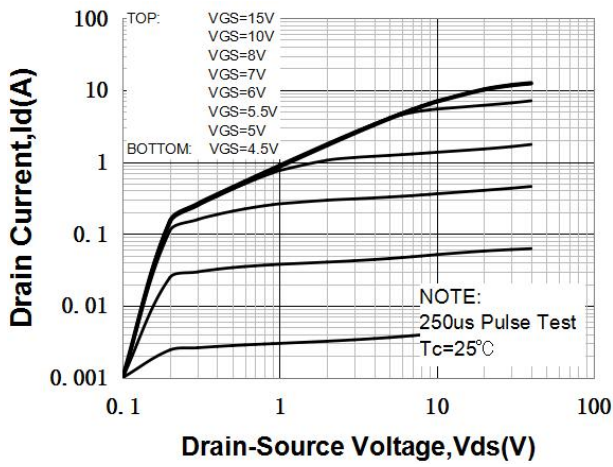

Fig1 Typical Output Characteristics, Tc=25°C

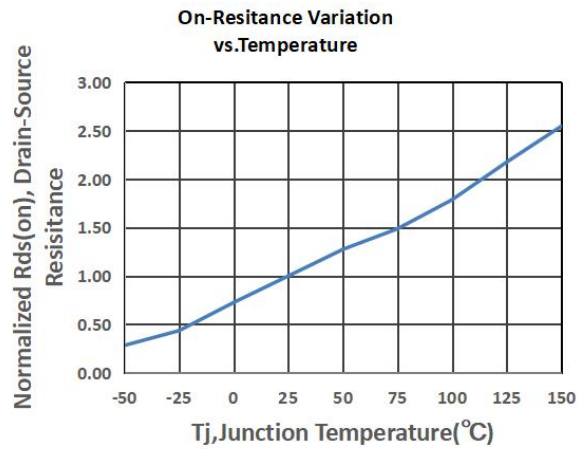

Fig2 Normalized On-Resistance Vs. Temperature

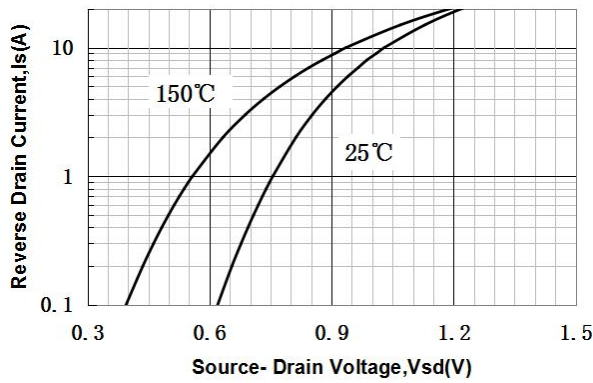

Fig3 Typical Source-Drain Diode Forward Voltage

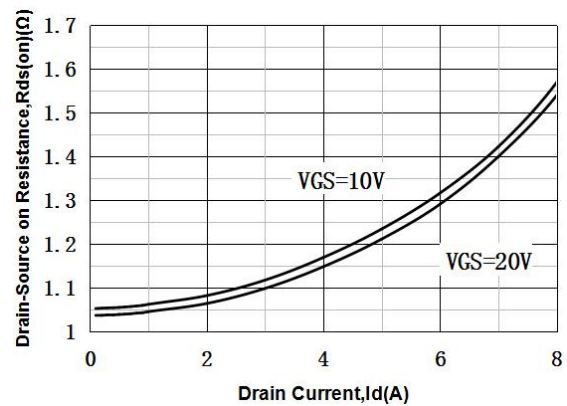

Fig4 On-Resistance Vs Drain Current and Gate Voltage

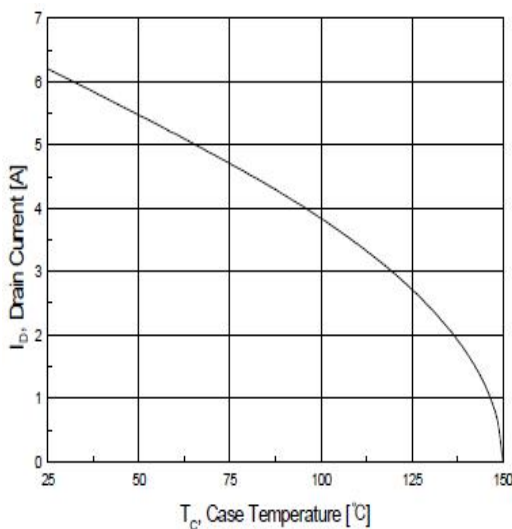

Fig5 Maximum Drain Current Vs. Case Temperature

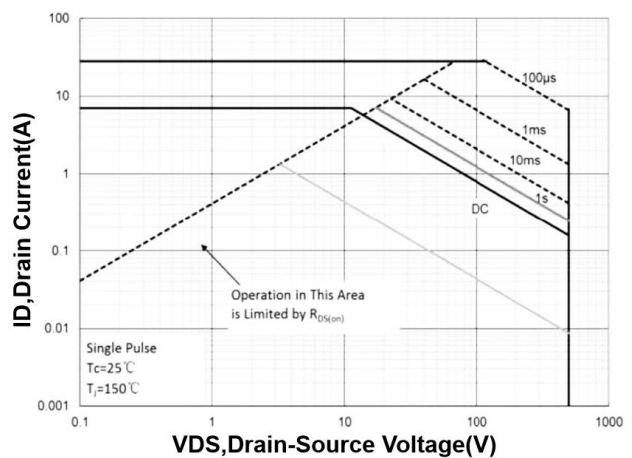
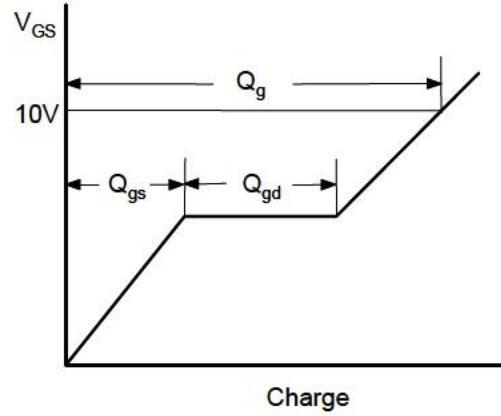
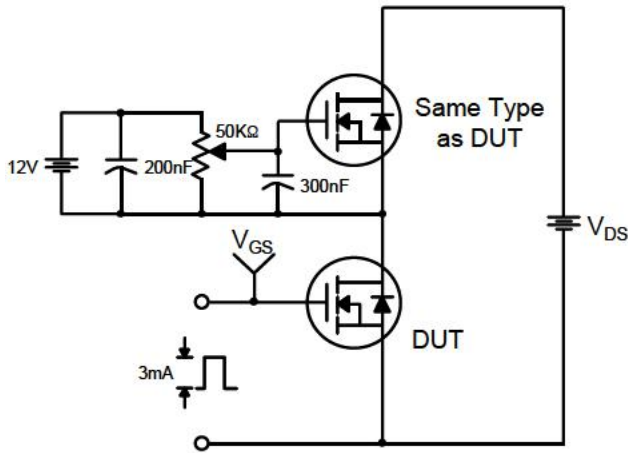
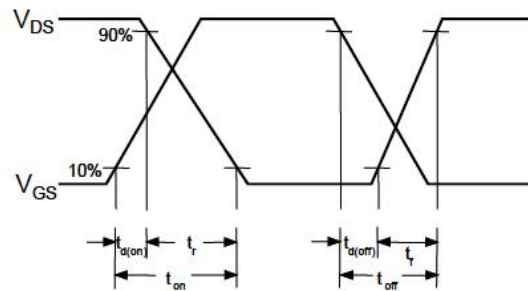
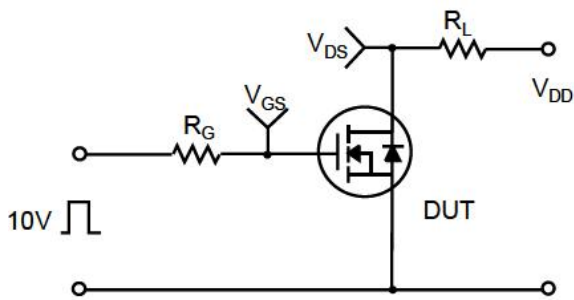

Fig6 Maximum Safe Operating Area

Gate Charge Test Circuit & Waveform



Resistive Switching Test Circuit & Waveforms



Unclamped Inductive Switching Test Circuit & Waveforms

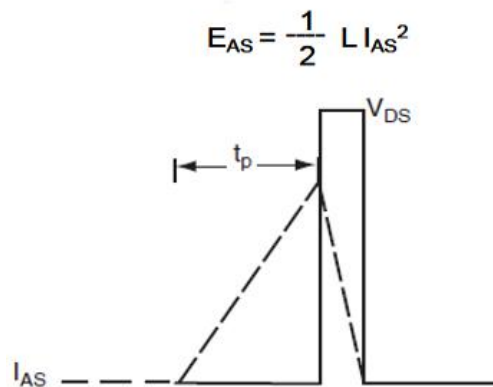
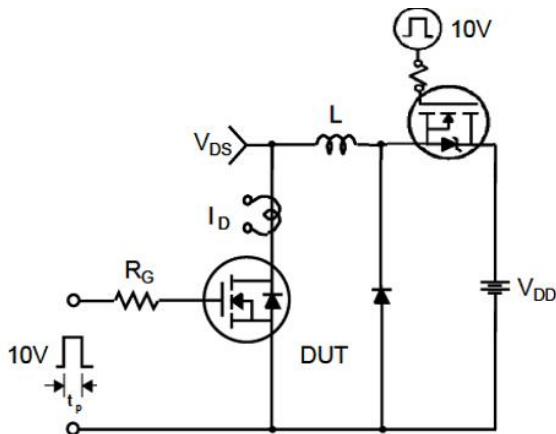

Package Mechanical Data-TO252-3L

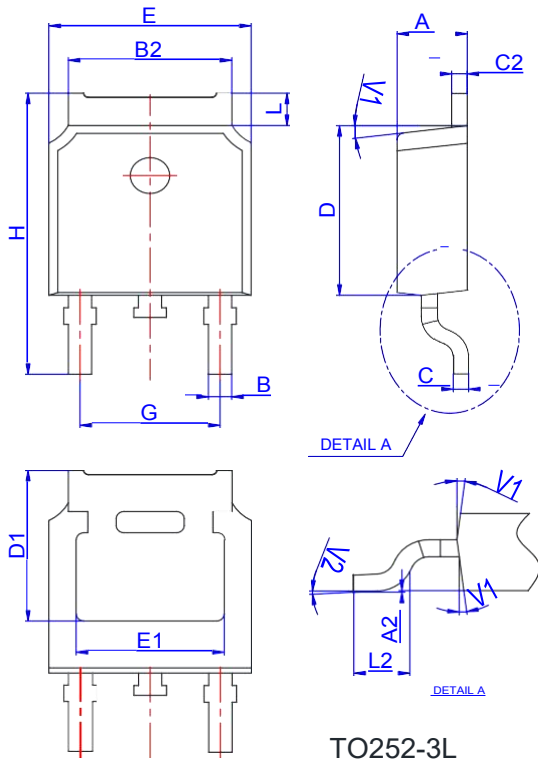

Ref.	Dimensions					
	Millimeters			Inches		
	Min.	Typ.	Max.	Min.	Typ.	Max.
A	2.10		2.50	0.083		0.098
A2	0		0.10	0		0.004
B	0.66		0.86	0.026		0.034
B2	5.18		5.48	0.202		0.216
C	0.40		0.60	0.016		0.024
C2	0.44		0.58	0.017		0.023
D	5.90		6.30	0.232		0.248
D1	5.30REF			0.209REF		
E	6.40		6.80	0.252		0.268
E1	4.63			0.182		
G	4.47		4.67	0.176		0.184
H	9.50		10.70	0.374		0.421
L	1.09		1.21	0.043		0.048
L2	1.35		1.65	0.053		0.065
V1		7°			7°	
V2	0°		6°	0°		6°

Reel Specification-TO252-3L

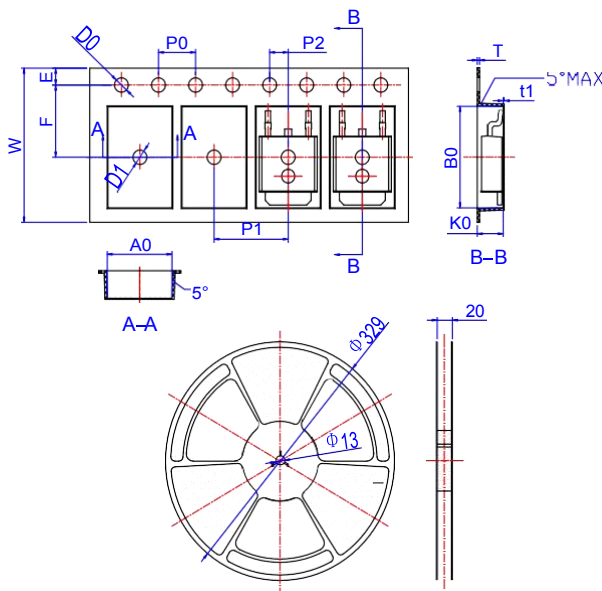

Ref.	Dimensions					
	Millimeters			Inches		
	Min.	Typ.	Max.	Min.	Typ.	Max.
W	15.90	16.00	16.10	0.626	0.630	0.634
E	1.65	1.75	1.85	0.065	0.069	0.073
F	7.40	7.50	7.60	0.291	0.295	0.299
D0	1.40	1.50	1.60	0.055	0.059	0.063
D1	1.40	1.50	1.60	0.055	0.059	0.063
P0	3.90	4.00	4.10	0.154	0.157	0.161
P1	7.90	8.00	8.10	0.311	0.315	0.319
P2	1.90	2.00	2.10	0.075	0.079	0.083
A0	6.85	6.90	7.00	0.270	0.271	0.276
B0	10.45	10.50	10.60	0.411	0.413	0.417
K0	2.68	2.78	2.88	0.105	0.109	0.113
T	0.24		0.27	0.009		0.011
t1	0.10			0.004		
10P0	39.80	40.00	40.20	1.567	1.575	1.583