

Features

- Split Gate Trench MOSFET technology
- Excellent package for heat dissipation
- High density cell design for low RDS(ON)

Product Summary



BVDSS	R _{DS(on)}	I _D
-100V	11mΩ	-120A

Applications

- DC-DC Converters
- Power management functions
- Synchronous-rectification applications

TO247 Pin Configuration

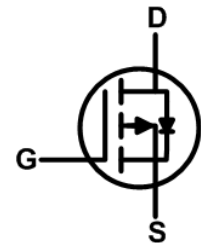
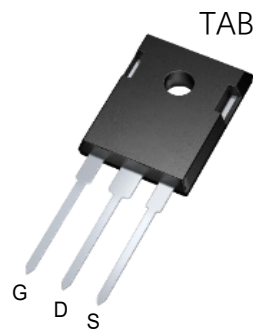

Absolute Maximum Ratings

Symbol	Parameter	Rating	Units
V _{DS}	Drain-Source Voltage	-100	V
V _{GS}	Gate-Source Voltage	±20	V
I _D @T _C =25°C	Continuous Drain Current, V _{GS} @ 10V ^{1,6}	-120	A
I _D @T _C =100°C	Continuous Drain Current, V _{GS} @ 10V ^{1,6}	-64	A
I _{DM}	Pulsed Drain Current ²	-600	A
EAS	Single Pulse Avalanche Energy ³	1458	mJ
I _{AS}	Avalanche Current	---	A
P _D @T _C =25°C	Total Power Dissipation ⁴	300	W
T _{STG}	Storage Temperature Range	-55 to 150	°C
T _J	Operating Junction Temperature Range	-55 to 150	°C

Thermal Data

Symbol	Parameter	Typ.	Max.	Unit
R _{θJA}	Thermal Resistance Junction-Ambient ¹	---	65	°C/W
R _{θJC}	Thermal Resistance Junction-Case ¹	---	0.50	°C/W

Electrical Characteristics (T_J=25 °C, unless otherwise noted)

Symbol	Parameter	Conditions	Min.	Typ.	Max.	Unit
BV _{DSS}	Drain-Source Breakdown Voltage	V _{GS} =0V, I _D =-250uA	-100	---	---	V
ΔBV _{DSS} /ΔT _J	BV _{DSS} Temperature Coefficient	Reference to 25°C, I _D =1mA	---	---	---	V/°C
R _{DS(ON)}	Static Drain-Source On-Resistance ²	V _{GS} =-10V, I _D =-22A	---	12	15	mΩ
V _{GS(th)}	Gate Threshold Voltage	V _{GS} =V _{DS} , I _D =-250uA	-2	-3	-4	V
ΔV _{GS(th)}	V _{GS(th)} Temperature Coefficient		---	---	---	mV/°C
I _{DSS}	Drain-Source Leakage Current	V _{DS} =-100V, V _{GS} =0V, T _J =25°C	---	---	1	uA
		V _{DS} =-100V, V _{GS} =0V, T _J =100°C	---	---	---	
I _{GSS}	Gate-Source Leakage Current	V _{GS} = ±20V, V _{DS} =0V	---	---	±100	nA
g _{fs}	Forward Transconductance	V _{DS} =-10V, I _D =-5A	---	---	---	S
R _g	Gate Resistance	V _{DS} =0V, V _{GS} =0V, f=1MHz	---	---	---	Ω
Q _g	Total Gate Charge	V _{DS} =-50V, V _{GS} =-10V, I _D =-5A	---	136	---	nC
Q _{gs}	Gate-Source Charge		---	36	---	
Q _{gd}	Gate-Drain Charge		---	24.8	---	
T _{d(on)}	Turn-On Delay Time	V _{GS} =-10V, V _{DS} =-50V, I _D =-22A, R _G =1Ω	---	18	---	ns
T _r	Rise Time		---	43	---	
T _{d(off)}	Turn-Off Delay Time		---	125	---	
T _f	Fall Time		---	43	---	
C _{iss}	Input Capacitance	V _{DS} =-50V, V _{GS} =0V, f=1MHz	---	9349	---	pF
C _{oss}	Output Capacitance		---	798	---	
C _{rss}	Reverse Transfer Capacitance		---	111.2	---	

Diode Characteristics

Symbol	Parameter	Conditions	Min.	Typ.	Max.	Unit
I _S	Continuous Source Current ^{1,4}	V _G =V _D =0V, Force Current	---	---	-120	A
V _{SD}	Diode Forward Voltage ²	V _{GS} =0V, I _S =-20A, T _J =25°C	---	---	-1.2	V
t _{rr}	Reverse Recovery Time	I _F =-20A, di/dt=100A/ μs, T _J =25°C	---	107	---	nS
Q _{rr}	Reverse Recovery Charge		---	216.8	---	nC

a1: Repetitive rating; pulse width limited by maximum junction temperature
a2: V_{DD}=-50V, L=1mH, R_G=25Ω, Starting T_j=25°C

Characteristics Curve:

Figure 1: Typ. output characteristics

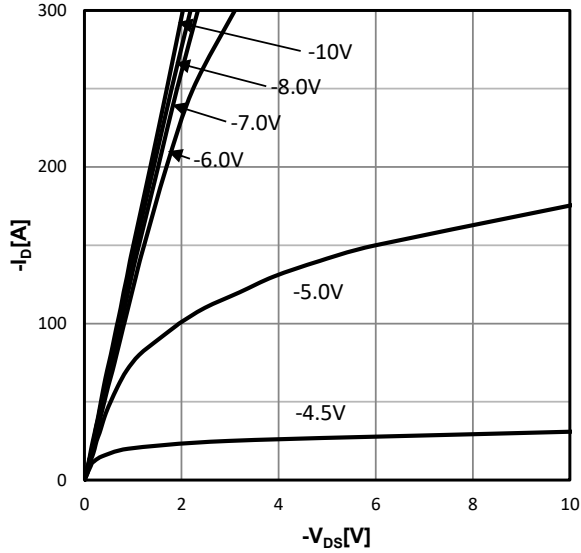

$I_D = f(V_{DS}), T_j = 25\text{ }^\circ\text{C}; \text{ parameter: } V_{GS}$

Figure 2: Typ. drain-source on resistance

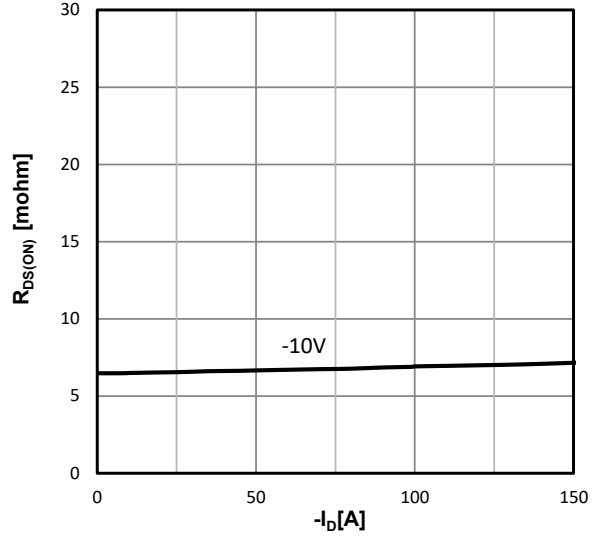

$R_{DS(on)} = f(I_D), T_j = 25\text{ }^\circ\text{C}; \text{ parameter: } V_{GS}$

Figure 3: Typ. transfer characteristics

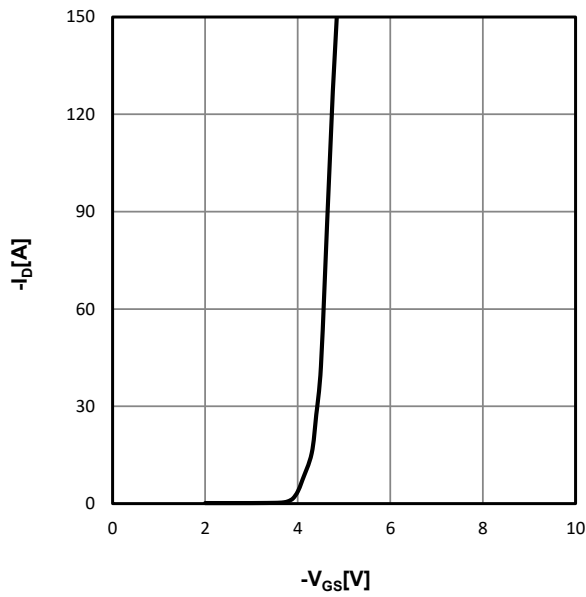

$I_D = f(V_{GS}), |V_{DS}| > 2|I_D|R_{DS(on)max}$

Figure 4: drain-source on resistance

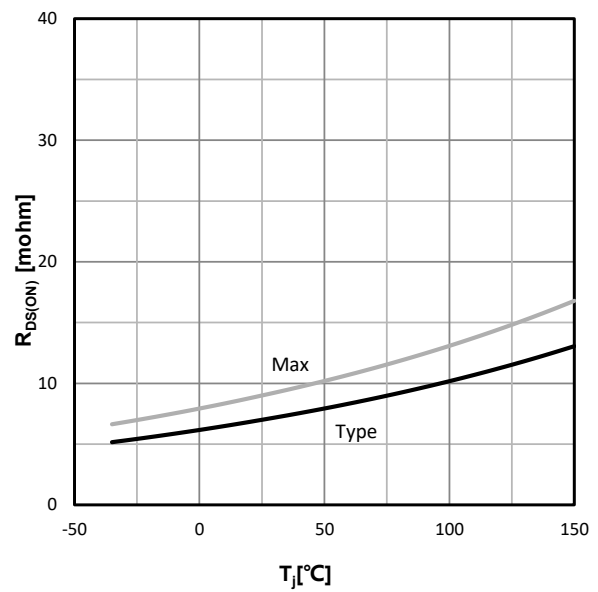

$R_{DS(on)} = f(T_j), I_D = -20\text{A}, V_{GS} = -10\text{V};$

Figure 5: Typ. gate threshold voltage

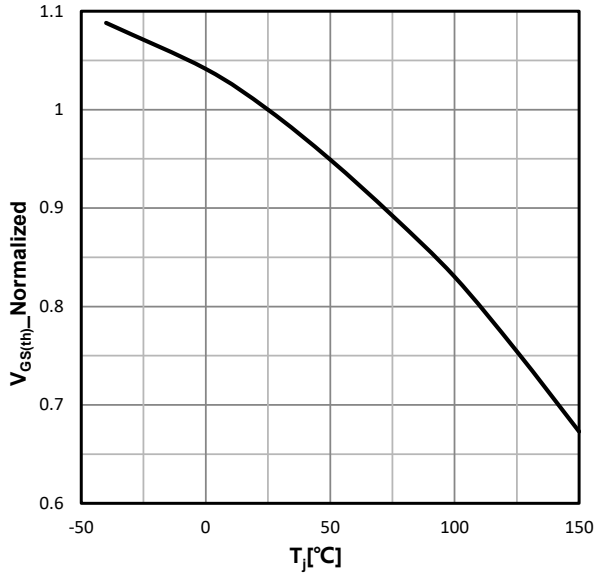

$V_{GS}=f(T_j), V_{GS}=V_{DS}, I_D=-250\mu A;$

Figure 6: Drain-source breakdown voltage

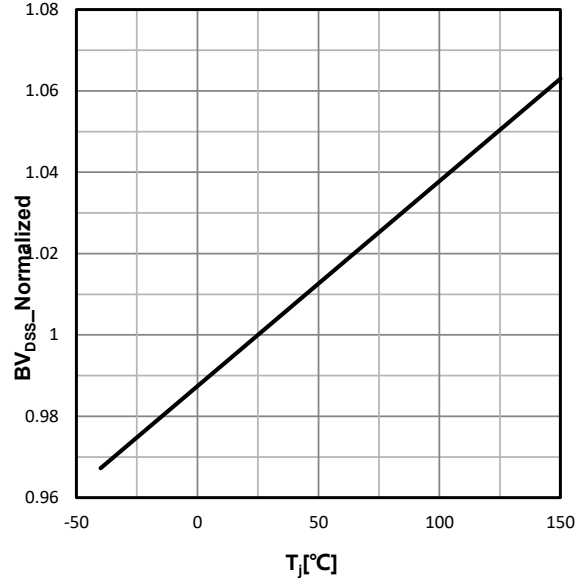

$V_{BR(DSS)}=f(T_j); I_D=-250\mu A;$

Figure 7: Typ. gate charge

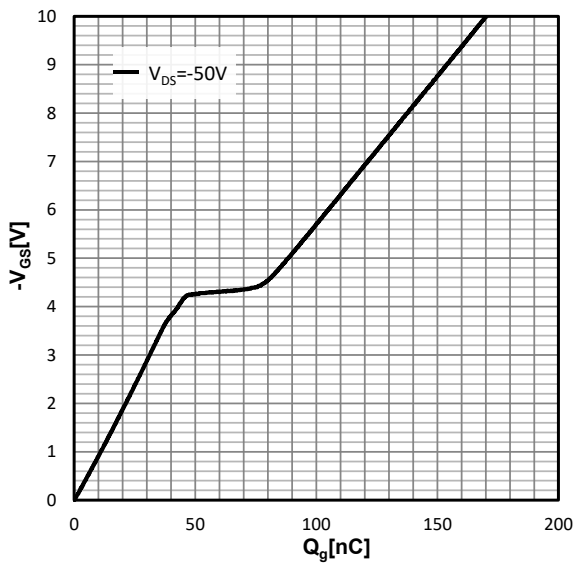

$V_{GS}=f(Q_g), I_D=-20A, T_j=25\text{ }^\circ\text{C};$ parameter: V_{DS}

Figure 8: Typ. Capacitances

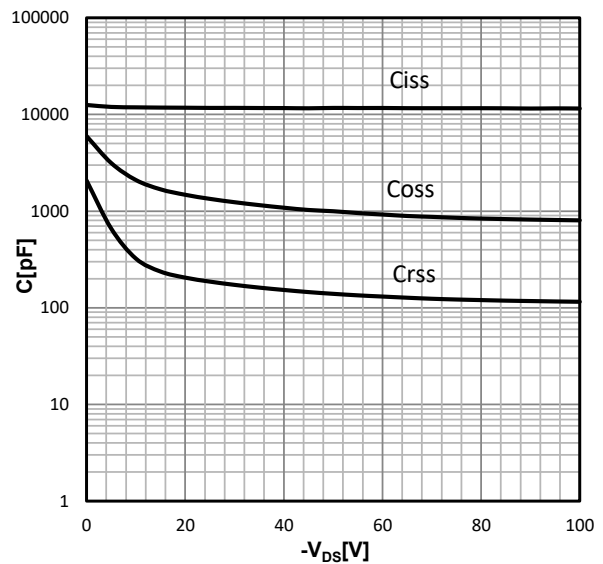

$C=f(V_{DS}); V_{GS}=0V; f=1.0\text{ MHz};$

Figure 9: Power dissipation

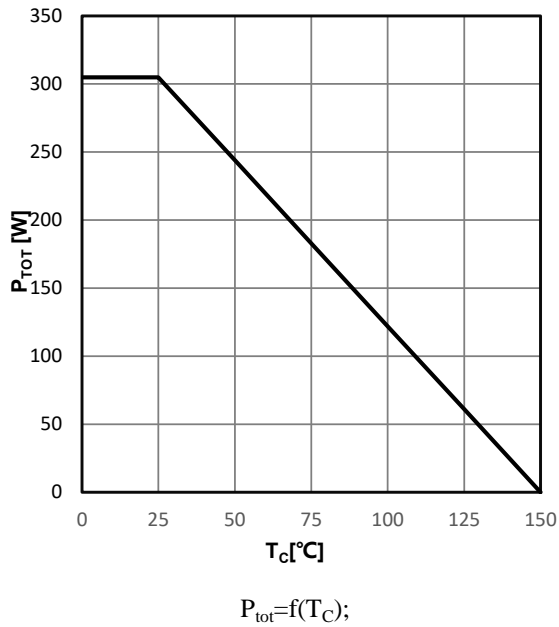

Figure 10: Drain current

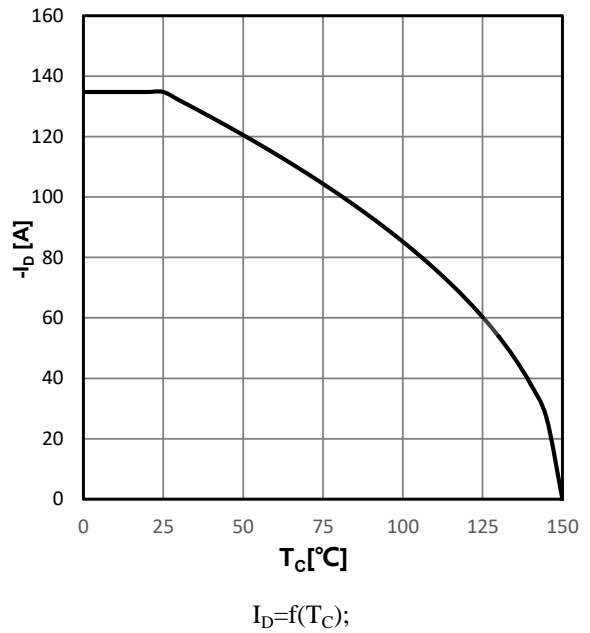

Figure 11: Safe operating area

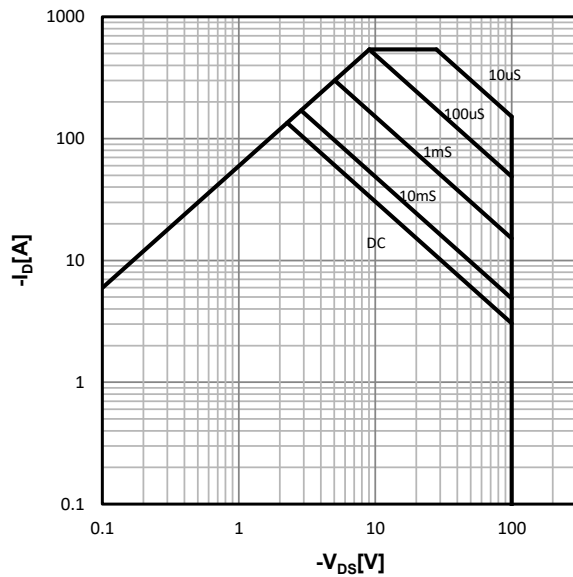

Figure 12: Typ. forward characteristics

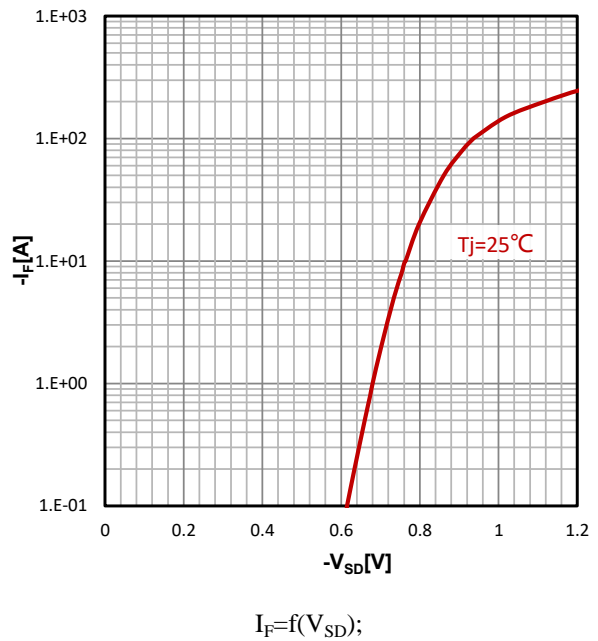
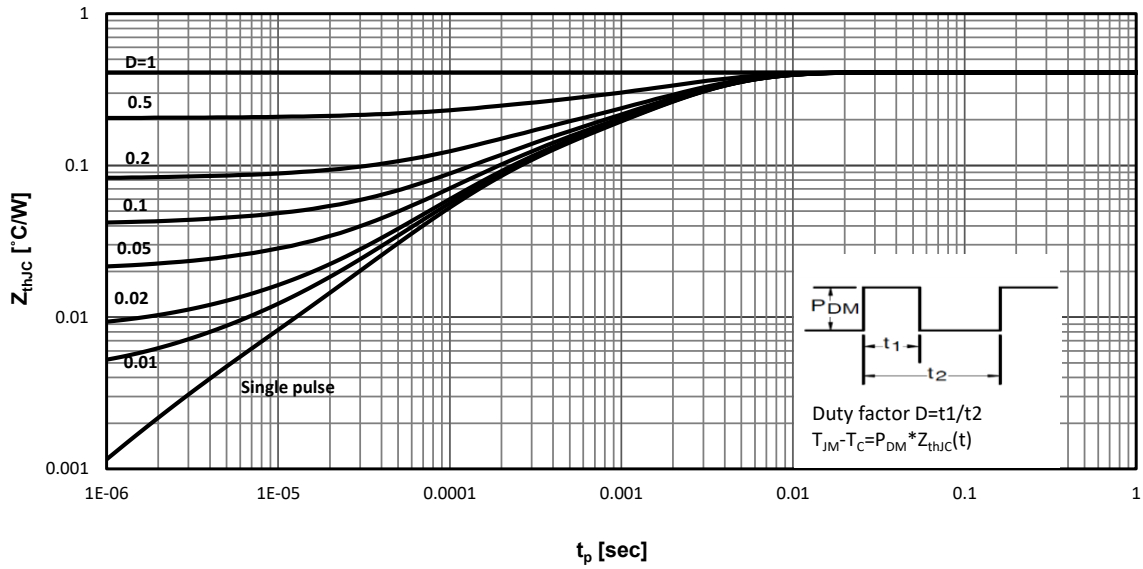

Figure 13: Max. Transient Thermal Impedance



$Z_{thJC}=f(t_p)$; parameter: D

Test Circuit and Waveform:

Gate Charge Test Circuit & Waveform

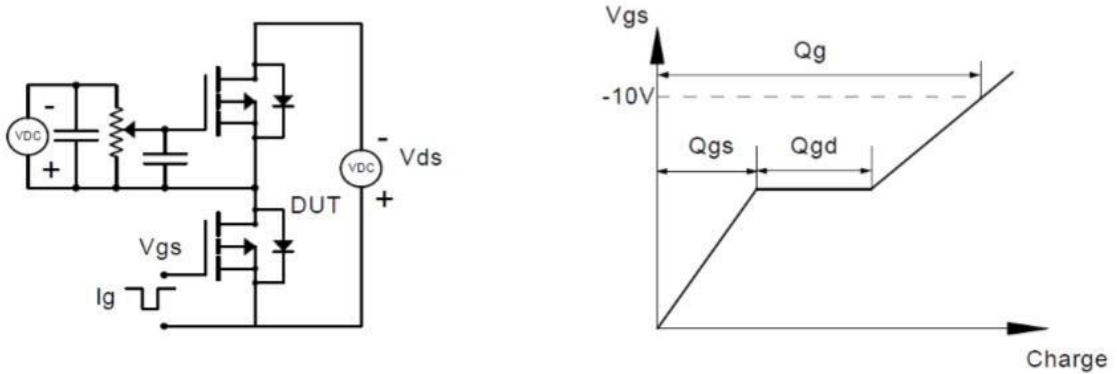

Resistive Switching Test Circuit & Waveforms

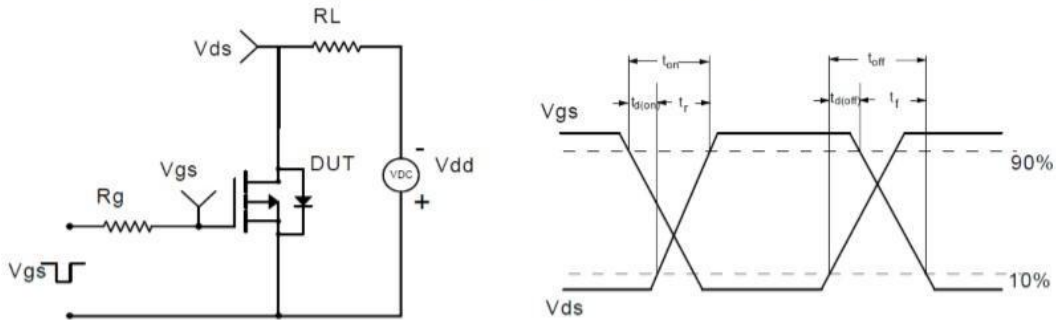

Unclamped Inductive Switching (UIS) Test Circuit & Waveforms

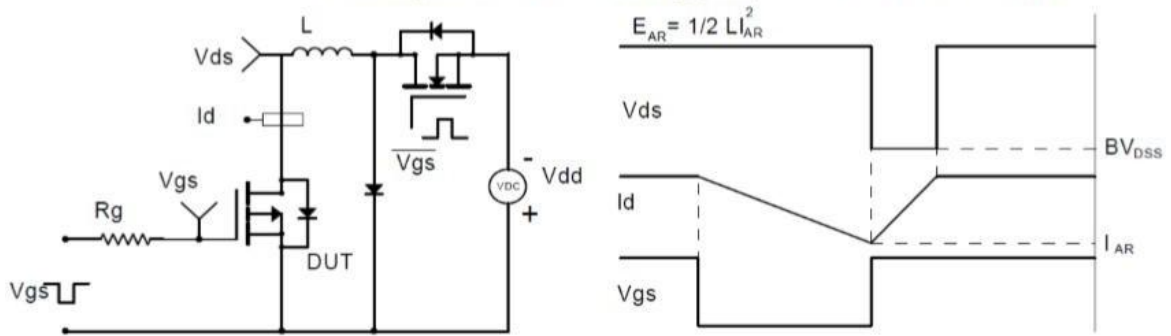

Diode Recovery Test Circuit & Waveforms

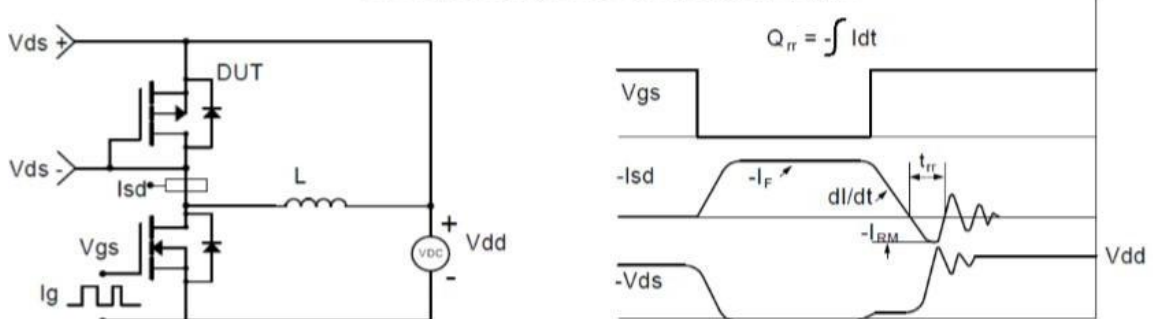

Mechanical Dimensions for TO-247

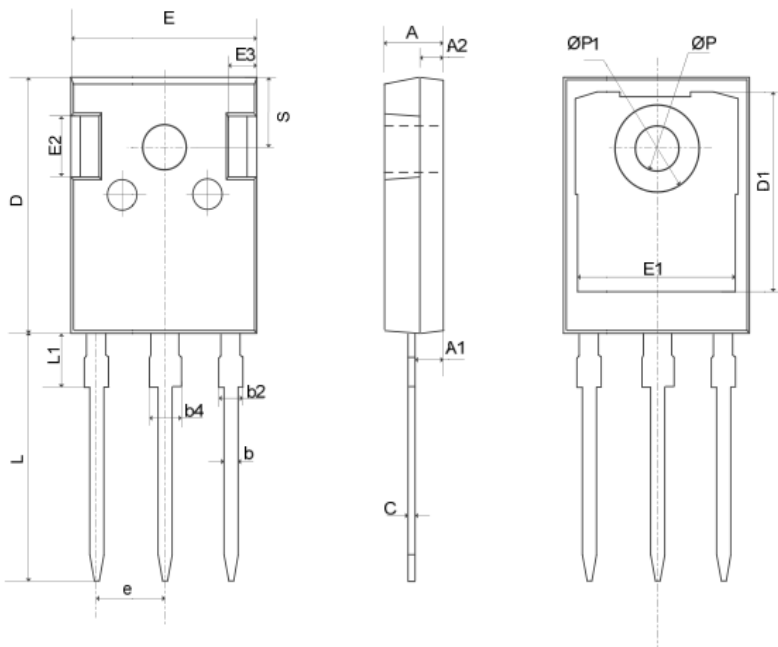

COMMON DIMENSIONS

SYMBOL	MM	
	MIN	MAX
A	4.80	5.20
A1	2.21	2.61
A2	1.85	2.15
b	1.11	1.36
b2	1.91	2.21
b4	2.91	3.21
c	0.51	0.75
D	20.70	21.30
D1	16.25	16.85
E	15.50	16.10
E1	13.00	13.60
E2	4.80	5.20
E3	2.30	2.70
e	5.44BSC	
L	19.62	20.22
L1	—	4.30
ØP	3.40	3.80
ØP1	—	7.30
S	6.15BSC	