

N-Ch 120V Fast Switching MOSFETs

Features

- Fast Switching
- Low Gate Charge and  $R_{DS(on)}$
- Low Reverse transfer capacitances

Product Summary



BVDSS	RDSON	ID
120V	12.5mΩ	80A

Applications

- DC-DC converter
- Portable Equipment
- Power management

TO252-3L Pin Configuration

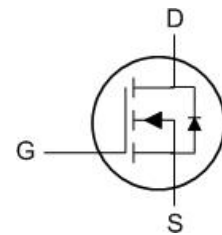
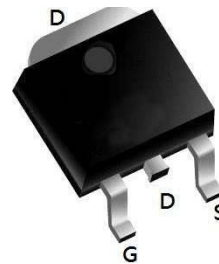

Absolute Maximum Ratings

Symbol	Parameter	Rating	Units
$V_{DS}$	Drain-Source Voltage	120	V
$V_{GS}$	Gate-Source Voltage	$\pm 20$	V
$I_D@T_C=25^\circ C$	Continuous Drain Current, $V_{GS} @ 10V^{1,6}$	80	A
$I_D@T_C=100^\circ C$	Continuous Drain Current, $V_{GS} @ 10V^{1,6}$	35	A
$I_{DM}$	Pulsed Drain Current <sup>2</sup>	160	A
EAS	Single Pulse Avalanche Energy <sup>3</sup>	105	mJ
$I_{AS}$	Avalanche Current	20.5	A
$P_D@T_C=25^\circ C$	Total Power Dissipation <sup>4</sup>	50	W
$T_{STG}$	Storage Temperature Range	-55 to 150	$^\circ C$
$T_J$	Operating Junction Temperature Range	-55 to 150	$^\circ C$

Thermal Data

Symbol	Parameter	Typ.	Max.	Unit
$R_{\theta JA}$	Thermal Resistance Junction-Ambient <sup>1</sup>	---	---	$^\circ C/W$
$R_{\theta JC}$	Thermal Resistance Junction-Case <sup>1</sup>	---	1.5	$^\circ C/W$

**Electrical Characteristics ( $T_J=25^\circ\text{C}$ , unless otherwise noted)**

Symbol	Parameter	Conditions	Min.	Typ.	Max.	Unit
$BV_{DSS}$	Drain-Source Breakdown Voltage	$V_{GS}=0V, I_D=250\mu A$	120	---	---	V
$\Delta BV_{DSS}/\Delta T_J$	$BV_{DSS}$ Temperature Coefficient	Reference to $25^\circ\text{C}$ , $I_D=1\text{mA}$	---	---	---	$V/^\circ\text{C}$
$R_{DS(ON)}$	Static Drain-Source On-Resistance <sup>2</sup>	$V_{GS}=10V, I_D=1A$	---	12.5	16.1	m $\Omega$
		$V_{GS}=4.5V, I_D=1A$	---	14.4	19	
$V_{GS(th)}$	Gate Threshold Voltage	$V_{GS}=V_{DS}, I_D=250\mu A$	1.4	2.0	2.6	V
$\Delta V_{GS(th)}$	$V_{GS(th)}$ Temperature Coefficient		---	---	---	$\text{mV}/^\circ\text{C}$
$I_{DSS}$	Drain-Source Leakage Current	$V_{DS}=120V, V_{GS}=0V, T_J=25^\circ\text{C}$	---	---	1	uA
		$V_{DS}=120V, V_{GS}=0V, T_J=125^\circ\text{C}$	---	---	100	
$I_{GSS}$	Gate-Source Leakage Current	$V_{GS}=\pm 20V, V_{DS}=0V$	---	---	$\pm 100$	nA
$g_{fs}$	Forward Transconductance	$V_{DS}=5V, I_D=84A$	---	---	---	S
$R_g$	Gate Resistance	$V_{DS}=0V, V_{GS}=0V, f=1\text{MHz}$	---	---	---	$\Omega$
$Q_g$	Total Gate Charge		---	27	---	nC
$Q_{gs}$	Gate-Source Charge	$V_{DS}=60V, V_{GS}=10V, I_D=30A$	---	5	---	
$Q_{gd}$	Gate-Drain Charge		---	6.3	---	
$T_{d(on)}$	Turn-On Delay Time		---	19	---	ns
$T_r$	Rise Time	$V_{DD}=60V, R_{G\_ext}=5\Omega,$	---	8	---	
$T_{d(off)}$	Turn-Off Delay Time	$V_{GS}=10V, I_D=20A$	---	72	---	
$T_f$	Fall Time		---	94	---	
$C_{iss}$	Input Capacitance		---	2225	---	pF
$C_{oss}$	Output Capacitance	$V_{DS}=60V, V_{GS}=0V, f=1\text{MHz}$	---	184	---	
$C_{rss}$	Reverse Transfer Capacitance		---	6	---	

**Diode Characteristics**

Symbol	Parameter	Conditions	Min.	Typ.	Max.	Unit
$I_S$	Continuous Source Current <sup>1,4</sup>	$V_G=V_D=0V$ , Force Current	---	---	80	A
$V_{SD}$	Diode Forward Voltage <sup>2</sup>	$V_{GS}=0V, I_S=84A, T_J=25^\circ\text{C}$	---	---	1.4	V
$t_{rr}$	Reverse Recovery Time	$I_F=40A, di/dt=100A/\mu s,$	---	52	---	nS
$Q_{rr}$	Reverse Recovery Charge	$T_J=25^\circ\text{C}$	---	113	---	nC

1. The data tested by surface mounted on a 1 inch<sup>2</sup> FR-4 board with 2OZ copper.

2. The data tested by pulsed, pulse width  $\leq 300\mu s$ , duty cycle  $\leq 2\%$

3. The EAS data shows Max. rating. The test condition is  $V_{DD}=25V, V_{GS}=10V, L=0.5\text{mH}$ ,

4. The power dissipation is limited by  $150^\circ\text{C}$  junction temperature

5. The data is theoretically the same as  $I_D$  and  $I_{DM}$ , in real applications, should be limited by total power dissipation.

Characteristics Curve:

Typ. output characteristics  
 $I_D=f(V_{DS})$

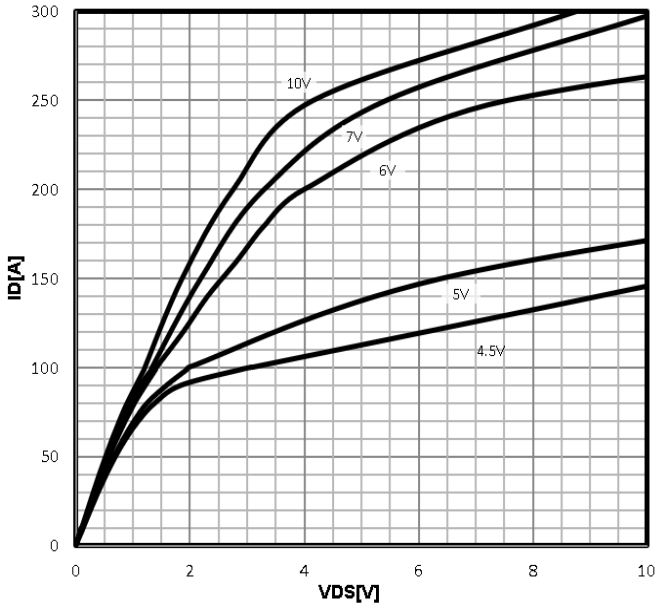

Typ. drain-source on resistance  
 $R_{DS(on)}=f(I_D)$

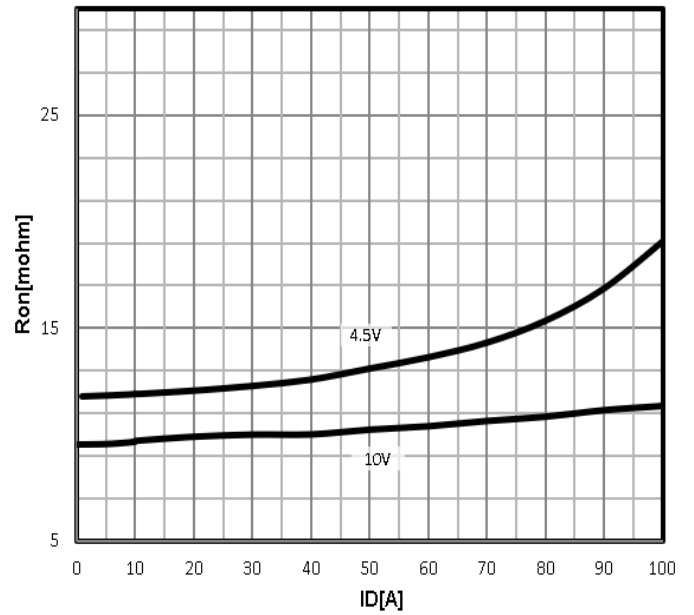

Typ. transfer characteristics  
 $I_D=f(V_{GS})$

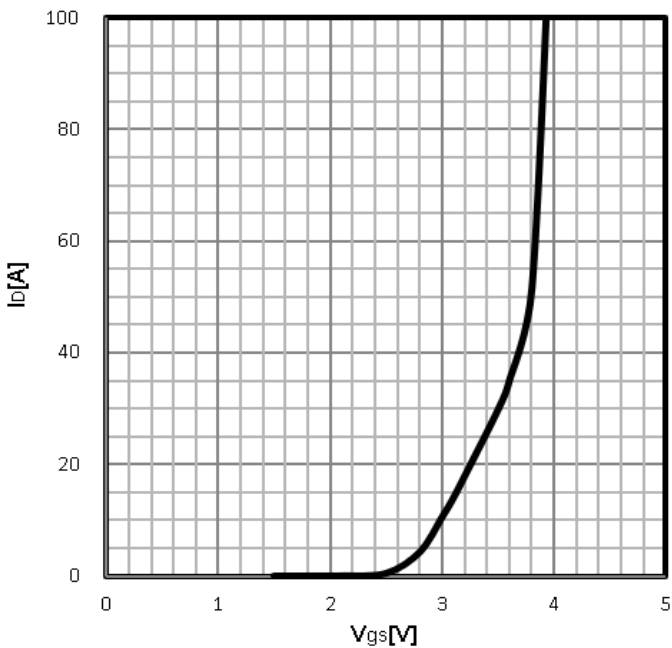

Drain-source on-state resistance  
 $R_{DS(on)}=f(T_j); I_D=20A; V_{GS}=10V$

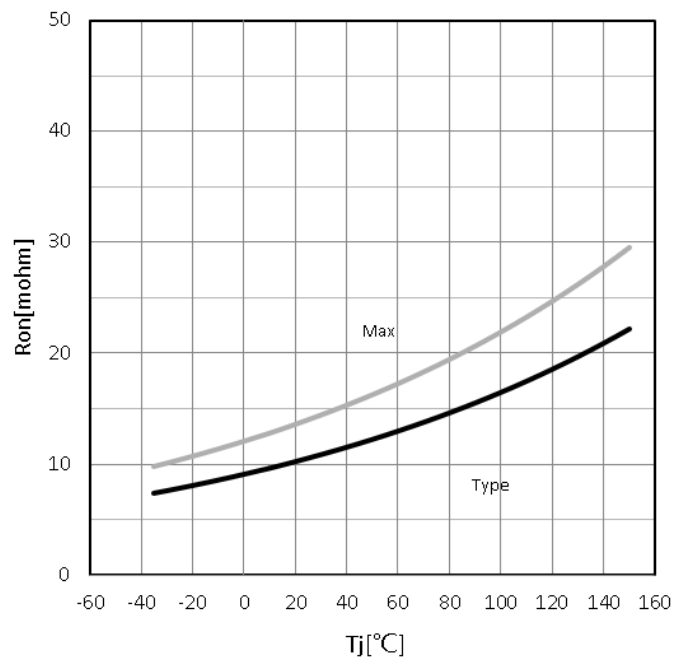

N-Ch 120V Fast Switching MOSFETs

**Gate Threshold Voltage**  
 $V_{TH}=f(T_j); I_D=250\mu A$

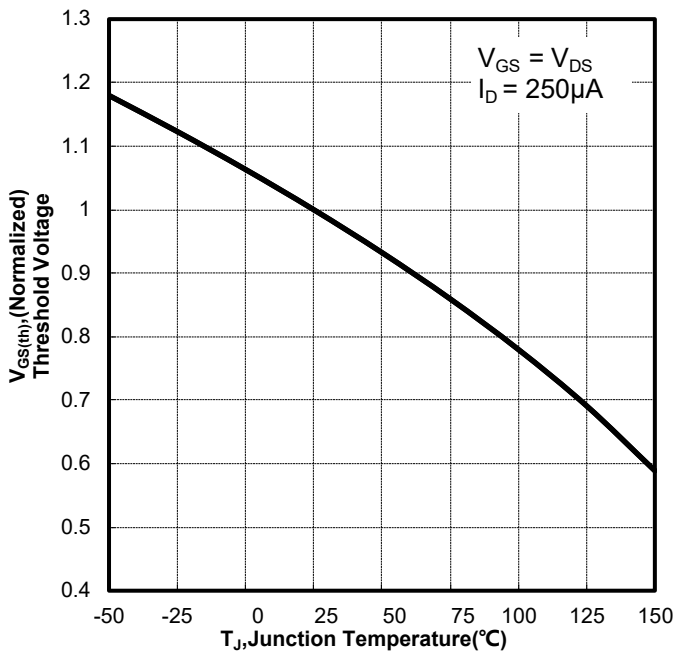

**Drain-source breakdown voltage**  
 $V_{BR(DSS)}=f(T_j); I_D=250\mu A$

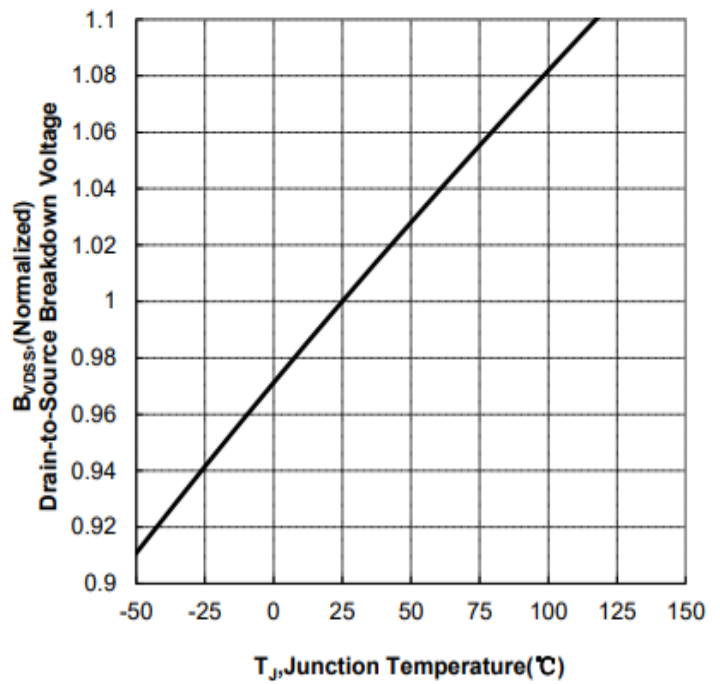

**Typ. gate charge**  
 $V_{GS}=f(Q_{gate})$

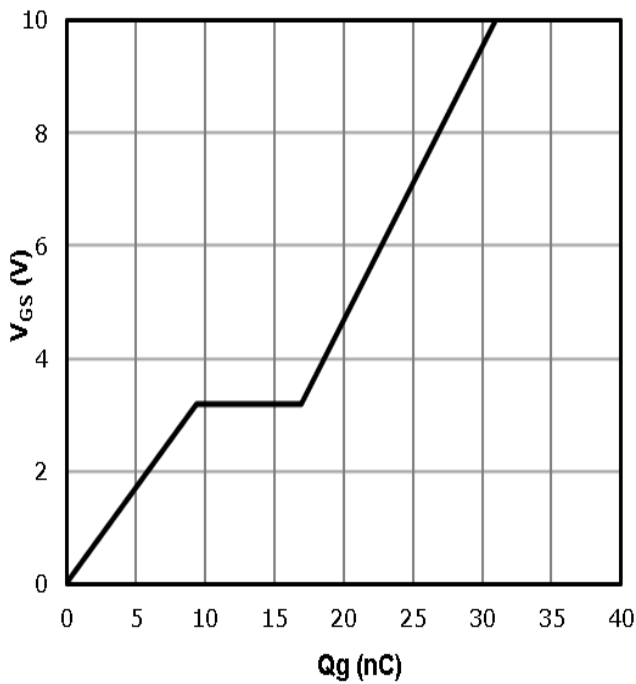

**Typ. capacitances**  
 $C=f(V_{DS}); V_{GS}=0V; f$

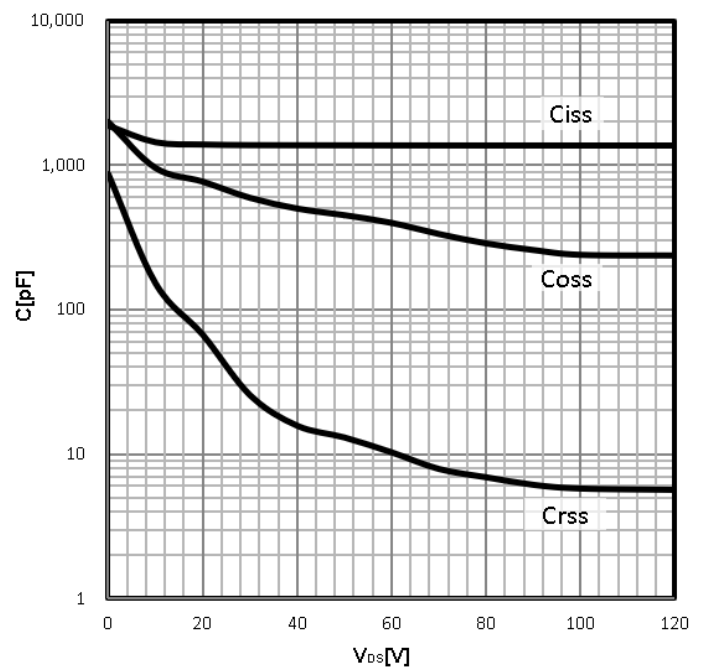

**Power Dissipation**  
 $P_{tot}=f(T_j)$

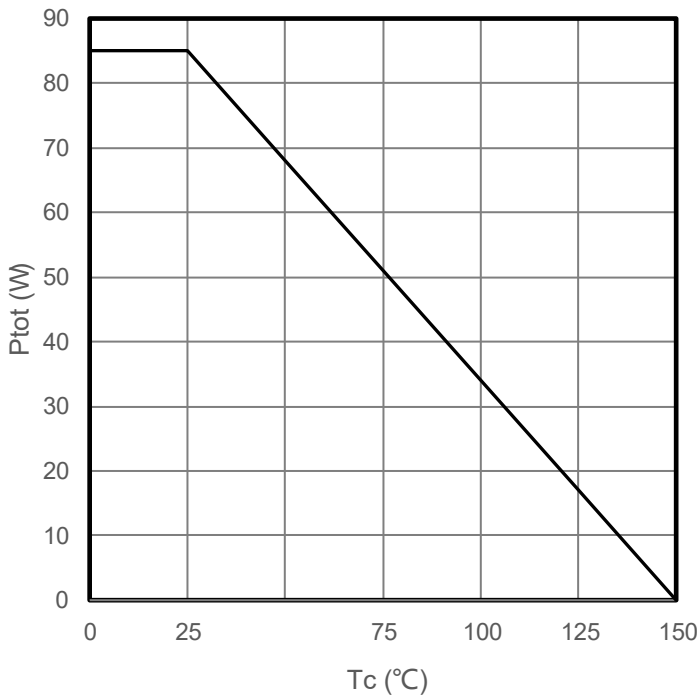

**Maximum Drain Current**  
 $I_D=f(T_c)$

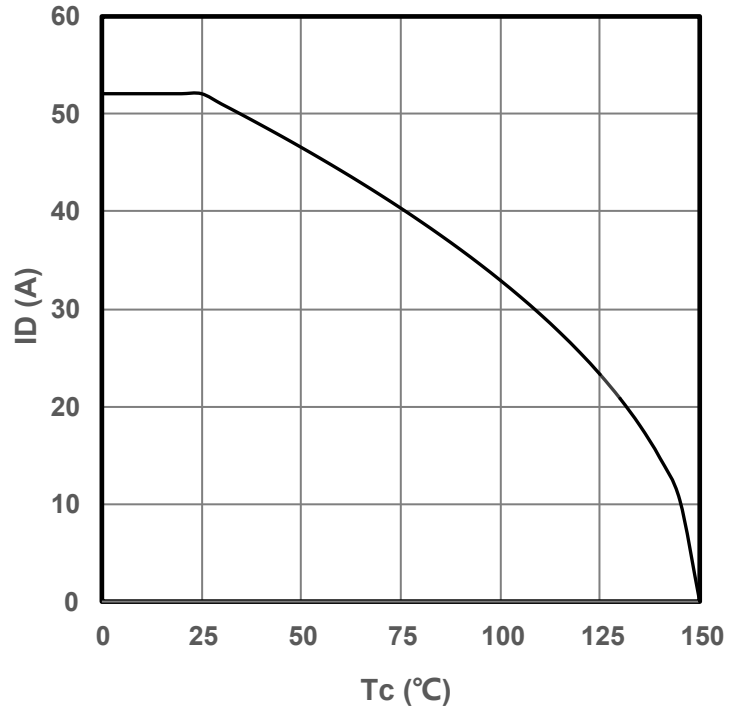

**Safe operating area**  
 $I_D=f(V_{DS})$

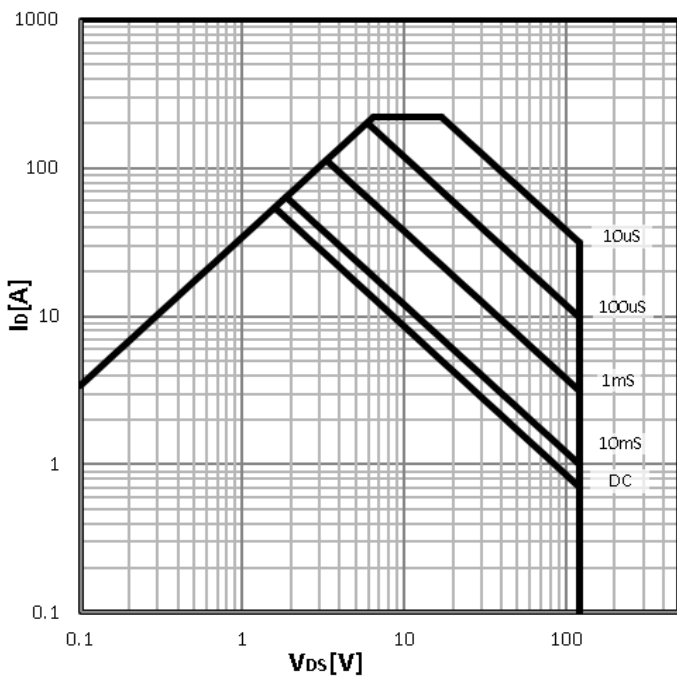

**Body Diode Forward Voltage Variation**  
 $I_F=f(V_{GS})$

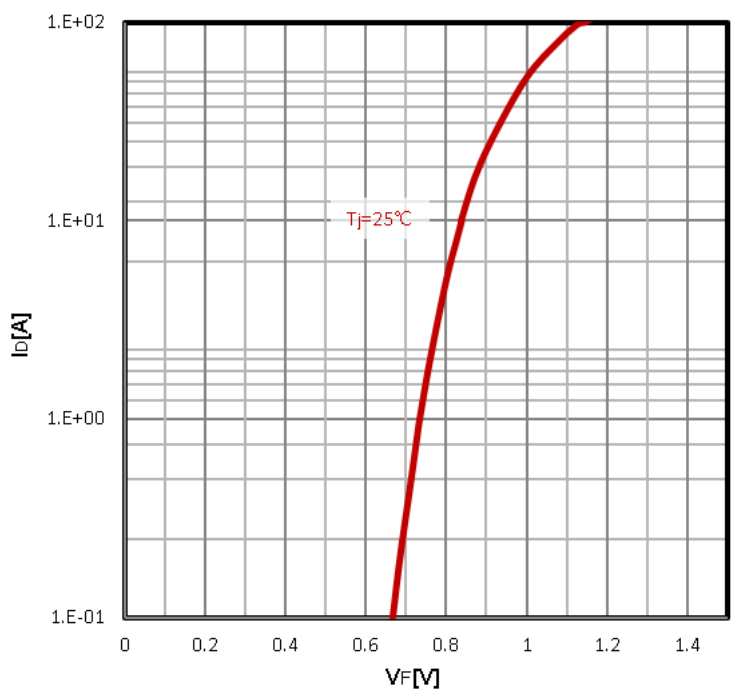

Max. transient thermal impedance

$$Z_{thJC} = f(t_p)$$

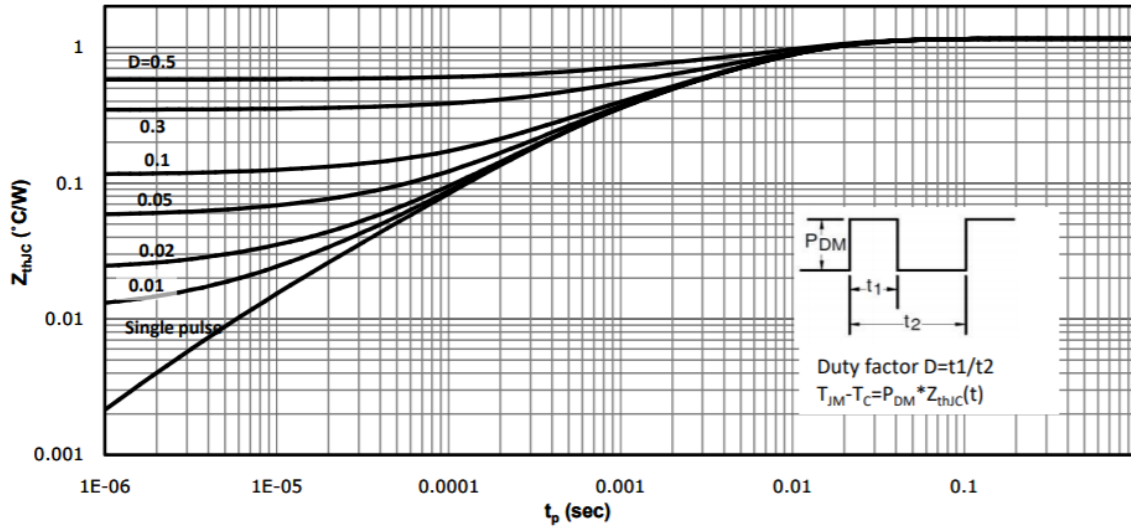

**Test Circuit and Waveform:**

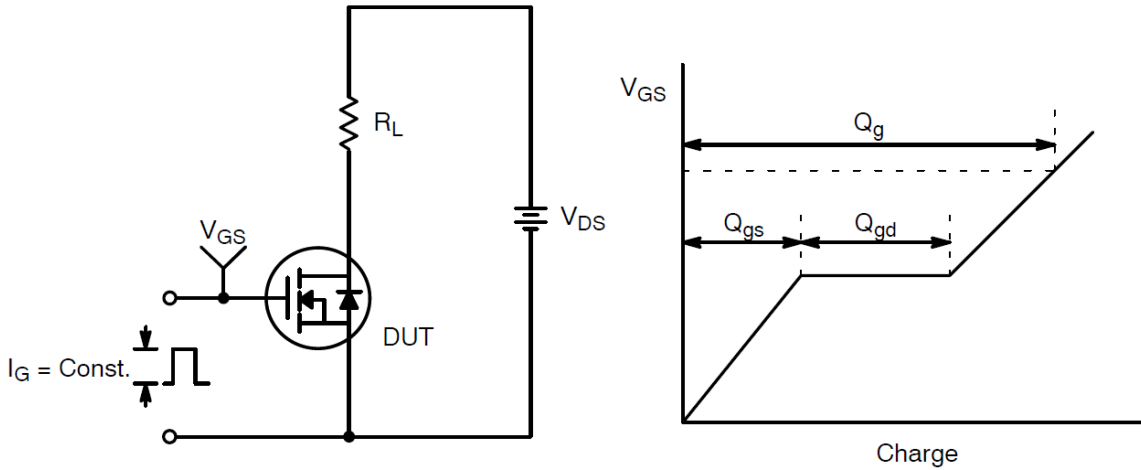

**Gate Charge Test Circuit & Waveform**

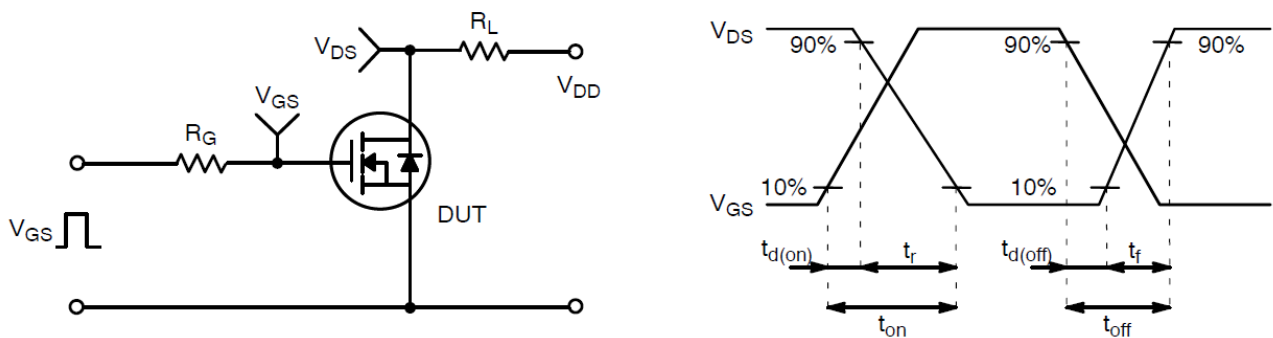

**Resistive Switching Test Circuit & Waveforms**

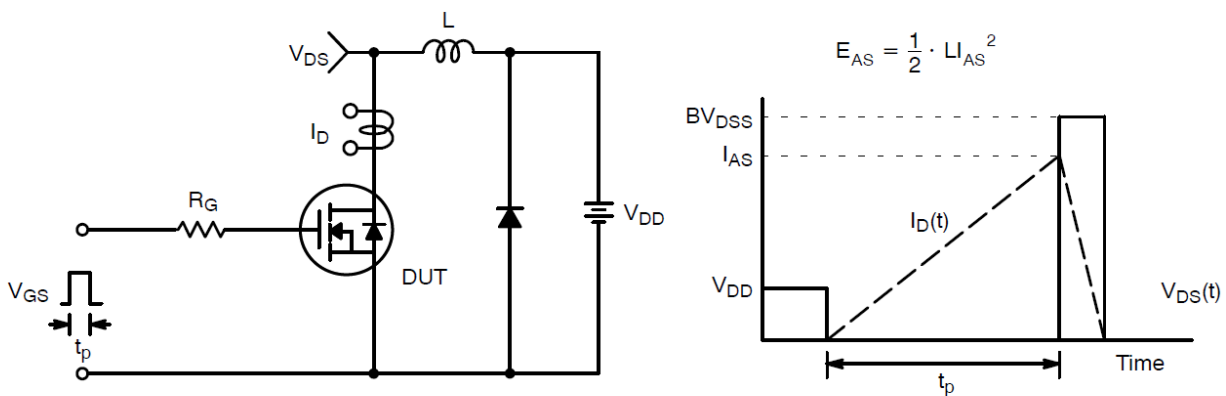

**Unclamped Inductive Switching Test Circuit & Waveforms**

Package Mechanical Data TO252-3L

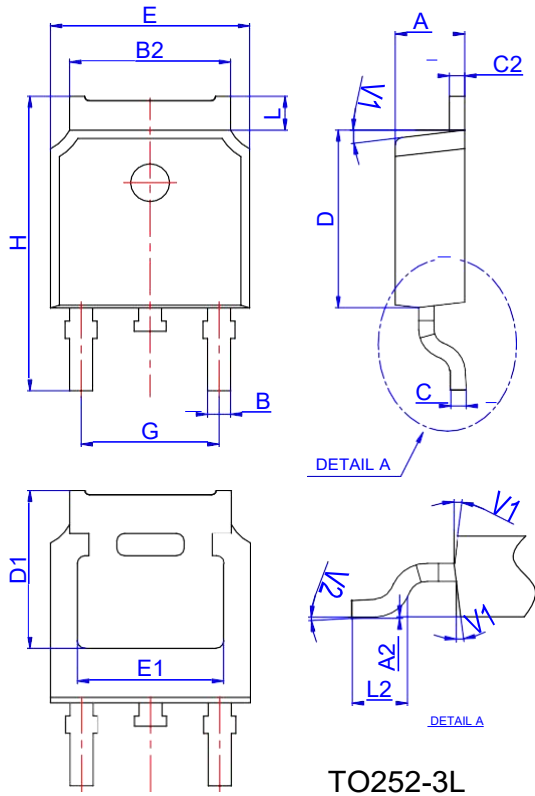

Ref.	Dimensions					
	Millimeters			Inches		
	Min.	Typ.	Max.	Min.	Typ.	Max.
A	2.10		2.50	0.083		0.098
A2	0		0.10	0		0.004
B	0.66		0.86	0.026		0.034
B2	5.18		5.48	0.202		0.216
C	0.40		0.60	0.016		0.024
C2	0.44		0.58	0.017		0.023
D	5.90		6.30	0.232		0.248
D1	5.30REF			0.209REF		
E	6.40		6.80	0.252		0.268
E1	4.63			0.182		
G	4.47		4.67	0.176		0.184
H	9.50		10.70	0.374		0.421
L	1.09		1.21	0.043		0.048
L2	1.35		1.65	0.053		0.065
V1		7°			7°	
V2	0°		6°	0°		6°

Reel Specification-TO252-3L

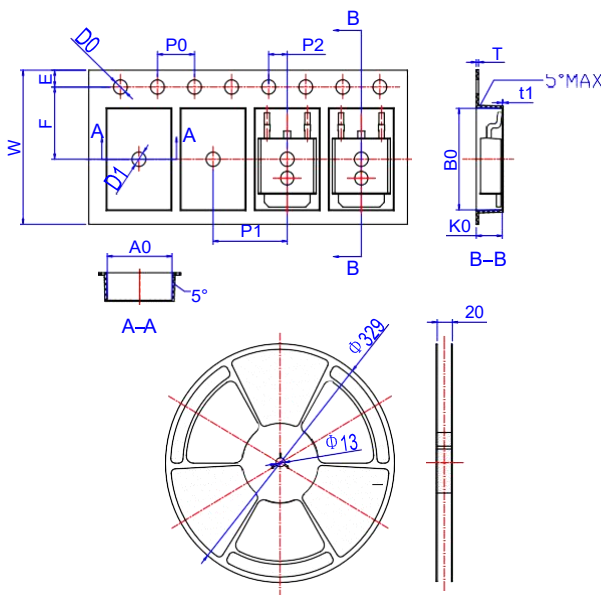

Ref.	Dimensions					
	Millimeters			Inches		
	Min.	Typ.	Max.	Min.	Typ.	Max.
W	15.90	16.00	16.10	0.626	0.630	0.634
E	1.65	1.75	1.85	0.065	0.069	0.073
F	7.40	7.50	7.60	0.291	0.295	0.299
D0	1.40	1.50	1.60	0.055	0.059	0.063
D1	1.40	1.50	1.60	0.055	0.059	0.063
P0	3.90	4.00	4.10	0.154	0.157	0.161
P1	7.90	8.00	8.10	0.311	0.315	0.319
P2	1.90	2.00	2.10	0.075	0.079	0.083
A0	6.85	6.90	7.00	0.270	0.271	0.276
B0	10.45	10.50	10.60	0.411	0.413	0.417
K0	2.68	2.78	2.88	0.105	0.109	0.113
T	0.24		0.27	0.009		0.011
t1	0.10			0.004		
10P0	39.80	40.00	40.20	1.567	1.575	1.583